

383Z

ENGINE

Make	YANMAR
Model	3TNV88-PNS, EPA TIER II
Type	3-cyl. water-cooled diesel
Displacement (cc)	100 cu.in. (1642)
Net Power (kW) @ rpm	28.8 hp (21.0) @ 2400 rpm
Battery (Ah)	12-V (71)
Fuel Tank (L)	11.6 gal (44)

HYDRAULIC SYSTEM

Pumps	two variable capacity + two gear pumps
Flow Rate (L/min)	2@ 10.6 gpm (40) + 7.0 gpm (26.3) + 3.0 gpm (11.3)
Working Pressure (bar)	3481 psi (240) all pumps
Swing System Pressure (bar)	3046 psi (210)
Oil Cooler	standard
Hydraulic Tank (L)	11.9 gal (45)

UNDERCARRIAGE AND SLEWING SYSTEM

Travel Speed - dual (km/h)	1.74 mph (2.8), 2.85 mph (4.6)
Gradability	30° = 58%
Rubber Track Width (mm)	(A) 12" (300)
No. of Track Rollers	1 top / 4 bottom on each side
Tracks Tension	hydraulic
Undercarriage Length	6'10" (2075)
Sprocket Center	(C) 5'7" (1702)
Ground Clearance (mm)	11" (280)
Ground Pressure - average (kg/cm ²)	4.8 psi (0.34)
Slew Speed	8.8 rpm

GENERAL SPECIFICATIONS

Operating Weight (kg)		
Cab with A/C		8,002 lbs (3630)
w/canopy		7,826 lbs (3550)
Dimensions (mm)		
Height / Width / Length	(D/E/F)	8'2" (2500) / 5'8" (1740) / 15'9" (4800)
Arm Length (mm)		5'5" (1650)
Max. Digging Depth (mm)	(G)	11'0" (3360)
Max. Digging Height (mm)	(H)	15'3" (4660)
Max. Vertical Digging Depth (mm)	(I)	8'9" (2670)
Max. Dump Height (mm)	(J)	11'0" (3350)
Max. Digging Radius (mm)	(K)	18'2" (5540)
Bucket Dig Force (kN)		5,778 lbf (25.7)
Arm Force (kN)		4,923 lbf (21.9)
Drawbar Pull (kN)		6,614 lbs. (3000)
Min. Tail Swing Radius (mm)	(L)	2'10" (870)
Min. Front Swing Radius (mm)	(M)	6'5" (1965)
Swing Angle - left/right	(N/O)	70°/55°

DOZER BLADE

Dimensions (mm)		
Width		5'8" (1740)
Height		13.6" (345)
Max. Lift (mm)		
Above / Below Ground	(Q/R)	15.4" (390) / 17.7" (450)

SOUND LEVELS

Power / Pressure Level	94 dB(A) / 78 dB(A)
------------------------	---------------------

* Denotes optional long dipper arm specifications. Lifting power is hydraulically limited.

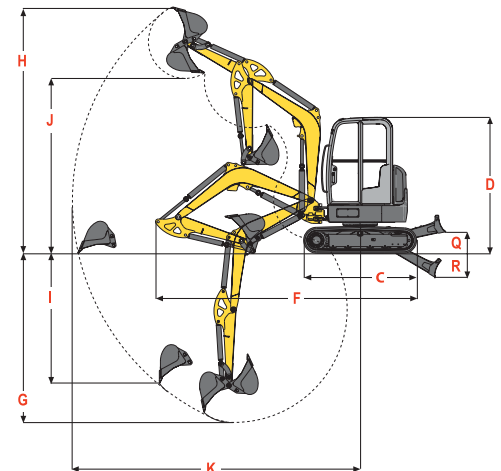

Reference Diagram

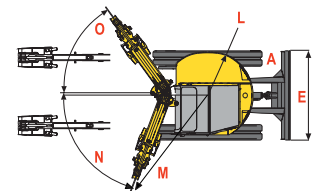

Gehl offers a full line of compact excavator models with operating weights ranging from 3560 to 25,397 lbs. New models with zero-tail-swing and short-tail-swing maneuverability offer some of the largest operator cabs in the industry. All models feature a unique combination of digging power, maneuverability, stability, visibility and operator comfort. The result—performance and profitability for you!

Contact your nearest Gehl dealer for more information.

GEHL®

COMPACT EQUIPMENT FOR BIG RESULTS™

www.gehl.com

143 Water Street
West Bend, WI 53095
U.S.A.

Tel: 262-334-9461
Fax: 262-338-7517

383Z

STANDARD EQUIPMENT



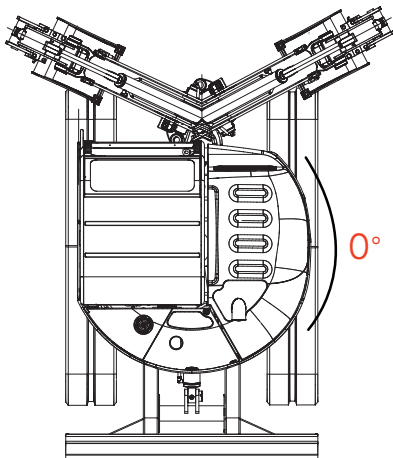









- Air-conditioned Cab with Heater
- Open Air Canopy
- 2-way Auxiliary Hydraulics with Flat-faced Couplers
- 3rd Return Line
- Advanced Hydraulic System
- Auto 2-speed Transmission
- Boom-mounted Worklight
- Two Variable-Displacement Pump and Two Gear Pumps
- Dozer Blade
- ROPS, FOPS and TOPS Cab and Canopy
- Hydraulic Oil Cooler
- Independent Boom Swing
- Pilot-operated Controls
- Rubber Tracks
- SAE/ISO Control Pattern Selection
- Suspension Seat
- Tool Kit



Zero-Tail-Swing Maneuverability

The Gehl Model 383Z features zero-tail-swing maneuverability without sacrificing operator comfort or service access. This allows operators to work easily on crowded jobsites without ever being in tight confines!

LIFTING CAPACITIES

		Maximum 		14'9" (4.5 m) 		11'6" (3.5 m) 		8'2" (2.5 m) 	
		Pounds (kg)		Pounds (kg)		Pounds (kg)		Pounds (kg)	
B	A								
	9'9" (3.0 m)								
6'6" (2.0 m)			1554 (705)	1047 (475)	1477 (670)	1477 (670)			
3'3" (1.0 m)	1664 (755)	893 (405)	1742 (790)	1014 (460)	2127 (965)	1477 (670)	3351 (1520)	2414 (1095)	
0 (0 m)	1653 (750)	882 (400)	1853 (845)	981 (445)	2579 (1170)	1400 (635)	4354 (1975)	2249 (1020)	
-3'3" (-1.5 m)					2590 (1175)	1367 (620)	4233 (1920)	2216 (1005)	
-6'6" (-3.0 m)							3461 (1570)	2260 (1025)	

A - Overhang from the center of the turntable
B - Height of load fixing point



- Dozer blade support in drive direction

- Dozer blade support 90° to drive direction

* - The lifting capacity is hydraulically limited

OPTIONAL EQUIPMENT

- Counterweight
- Radio
- Roof-mounted Worklights
- Travel Alarm

GEHL
www.gehl.com

SAFETY IS NO ACCIDENT.

Gehl Company reminds users to read and understand the operator's manual before operating any piece of equipment. Additionally, be sure all safety devices and shields are securely in place and functioning properly.

Gehl Company reserves the right to make changes in design or specifications at any time without notice or obligation.