

ENGINE

Make	YANMAR
Model	4TNV98-VNS, EPA TIER II
Type	4-cyl. water-cooled diesel
Displacement (cc)	202 cu. in. (3318)
Power (kW) - Gross / Net @ rpm	69 hp (51.1) / 57 hp (42.5) @ 2100 rpm
Battery (Ah)	12-V (88)
Fuel Tank (L)	21.9 gal (83)

HYDRAULIC SYSTEM

Pumps	two variable capacity + two gear pumps
Flow Rate (L/min)	2@ 16.9 gpm (64.1) + 12.7 gpm (48) + 2.7 gpm (10.3)
Working Pressure (bar)	3553 psi (245)
Swing System Pressure (bar)	3118 psi (215)
Oil Cooler	standard
Hydraulic Tank (L)	21.1 gal (80)

UNDERCARRIAGE AND SLEWING SYSTEM

Travel Speed - dual (km/h)	1.73 mph (2.8), 2.92 mph (4.7)
Gradability	30° = 58%
Rubber Track Width (mm)	(A) 15.7" (400)
No. of Track Rollers	5 on each side
Tracks Tension	hydraulic
Undercarriage Length (mm)	(C) 8'2" (2500)
Sprocket Center (mm)	6'7" (2000)
Ground Clearance (mm)	11.4" (290)
Ground Pressure - average (kg/cm ²)	4.7 psi (0.33)
Slew Speed	9 rpm

GENERAL SPECIFICATIONS

Operating Weight (kg)	12,566 lbs (5700)
Dimensions (mm)	
Height / Width	(D/E) 8'5" (2570) / 6'6" (1990)
Transport Length	(F) 19' (5800)
Arm Length (mm)	5'6" (1685)
w/long arm - optional	6'6" (1985)
Max. Digging Depth (mm)	(G) 12'7" (3845)
w/long arm	(G*) 13'7" (4140)
Max. Digging Height (mm)	(H) 18'7" (5660)
w/long arm	(H*) 19'2" (5850)
Max. Vertical Digging Depth (mm)	(I) 9'4" (2855)
w/long arm	(I*) 10'3" (3135)
Max. Dump Height (mm)	(J) 12'2" (3720)
w/long arm	(J*) 13'1" (3995)
Max. Digging Radius (mm)	(K) 19'9" (6030)
w/long arm	(K*) 20'4" (6210)
Bucket Dig Force (kN)	8296 lbf (39.7)
Arm Force (kN)	6317 lbf (28.1)
Min. Tail Swing Radius (mm)	(L) 3'3" (990)
Min. Front Swing Radius (mm)	(M) 7' (2140)
Swing Angle - left / right	(N/O) 75° / 51°

DOZER BLADE

Dimensions - Width / Height (mm)	6'6" (1990) / 16.7" (425)
Max. Lift - Above / Below Ground (mm)	(Q/R) 15.4" (390) / 15.7" (400)

GENERAL PURPOSE BUCKET OPTIONS

Width (mm) / Capacity (L)	12" (305) / 2.5 cu.ft. (71)
	16" (406) / 3.3 cu.ft. (93)
	20" (508) / 3.7 cu.ft. (105)
	26" (660) / 6.4 cu.ft. (181)
	33" (838) / 8.8 cu.ft. (250)

SOUND LEVELS

Power / Pressure Level	101 dB(A) / 78 dB(A)
------------------------	----------------------

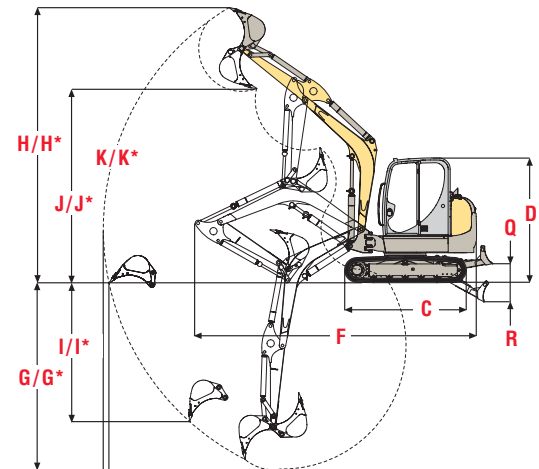

Reference Diagram

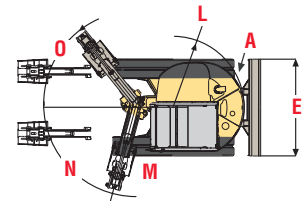

Gehl offers a full line of compact excavator models with operating weights ranging from 3560 to 25,397 lbs. New models with zero tail swing and short tail swing maneuverability offer some of the largest operator cabs in the industry. All models feature a unique combination of digging power, maneuverability, stability, visibility and operator comfort. The result—performance and profitability for you!

Contact your nearest Gehl dealer for more information.

GEHL

COMPACT EQUIPMENT FOR BIG RESULTS™

www.gehl.com

143 Water Street
West Bend, WI 53095
U.S.A.

Tel: 262-334-9461
Fax: 262-338-7517

* Denotes optional long dipper arm specifications. Lifting power is hydraulically limited.

603

STANDARD EQUIPMENT

- Enclosed ROPS Cab
- Advanced Hydraulic System
- Hydraulic Oil Cooler
- Pilot-operated Joystick Control
- Heating System
- Double Variable Displacement Pump
- Boom-mounted Worklight
- Suspension Seat
- Tool Kit
- Rubber Tracks
- SAE/ISO Control Pattern Selection
- Auto 2-Speed Transmission
- Auxiliary Hydraulic with Flat-faced Couplers
- 3rd Return Line
- Independent Boom Swing
- Dozer Blade



Feel confident in tight spaces with independent boom swing and a full panoramic view from the operator's cab. Take the Model 603 to more places with the new shorter tail swing.

LIFTING CAPACITIES

	Maximum		16'5" (5.0 m)		13'1" (4.0 m)		9'10" (3.0 m)		6'7" (2.0 m)	
	Pounds (kg)		Pounds (kg)		Pounds (kg)		Pounds (kg)		Pounds (kg)	
A										
B										
13'1" (4.0 m)	2888 * (1310)	2249 (1020)			2745 * (1245)	2546 (1155)				
9'2" (3.0 m)	2866 * (1300)	1775 (805)			2789 * (1265)	2524 (1145)				
6'7" (2.0 m)	2910 * (1320)	1565 (710)	2932 * (1330)	1709 (775)	3285 * (1490)	2425 (1100)	4156 * (1885)	3748 (1700)		
3'3" (1.0 m)	2998 * (1360)	1488 (675)	3164 * (1435)	1653 (750)	3913 * (1775)	2282 (1035)	5765 * (2615)	3417 (1550)		
0 (0 m)	3109 * (1410)	1521 (690)	3296 * (1495)	1609 (730)	4343 * (1970)	2183 (990)	6548 * (2970)	3241 (1470)		
-3'3" (-1.0 m)	3230 * (1465)	1676 (760)			4332 * (1965)	2138 (970)	6415 * (2910)	3197 (1450)	11045 * (5010)	6162 (2795)
-6'7" (-2.0 m)	3296 * (1495)	2127 (965)					5401 * (2450)	3252 (1475)	8830 (4005)	6294 (2855)

A - Overhang from the center of the turntable
 B - Height of load fixing point

* - The lifting capacity is hydraulically limited



- Dozer blade support in drive direction

- Dozer blade support 90° to drive direction

OPTIONAL EQUIPMENT

- Air Conditioning
- Counterweight
- Steel Tracks
- Long Dipper Arm

GEHL

www.gehl.com

SAFETY IS NO ACCIDENT.

Gehl Company reminds users to read and understand the operator's manual before operating any piece of equipment. Additionally, be sure all safety devices and shields are securely in place and functioning properly.

Gehl Company reserves the right to make changes in design or specifications at any time without notice or obligation.